

HYDRAJAWS® M2050

Oil Refilling Instructions



Connecting and disconnecting Gauges from the Tester body will eventually use up the spare oil capacity and will not allow the tester plunger to travel it's full stroke or give an accurate reading on the Gauge.

! NOTE: A tester with a fixed gauge cannot be filled with oil by the operator.

To replenish the oil level:

1. Remove the bridge and all accessories.
2. Secure the tester (e.g. in a vice or other suitable holding device if on-site) with the coupler in the vertical position.
3. Connect the oil bottle via the quick release coupler.
4. Loosen bottle cap (**fig 1**).
5. Turn the handle anti-clockwise a few turns then using the piston key provided insert this into the groove on the piston. Ensure the piston key outer slot is nearer the piston body (**fig 2**).
6. Force any air out of the system by pushing the piston in fully then pull on the piston key and handle until 10mm away from the inside of the slot. This will draw oil from the bottle (**fig 3**).
7. Push the piston back in fully, pull out again and repeat until all the air bubbles are expelled into the bottle, the oil is replenished, and piston is 10mm from face of the Body.
8. Remove oil bottle.

! Ensure not to pull the piston out further than 15mm.



Recommended oil: Light Mineral DTE Type

Fig 1

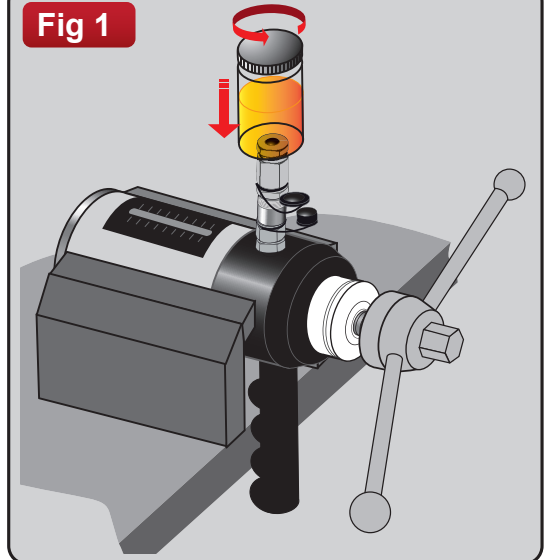

Fig 2

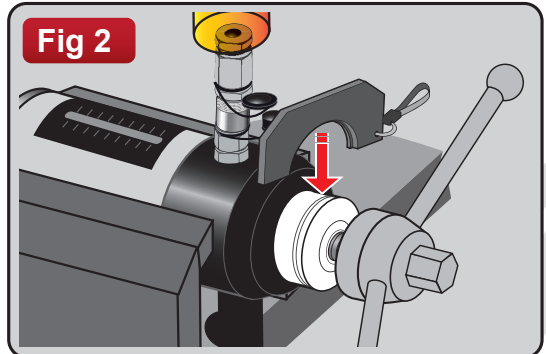

Fig 3

